

Joint Engineering Examination Scholarship Entrance Test  
JEESET is a National Level Scholarship Test

[www.jeeset.com](http://www.jeeset.com)

## Sample Paper for JEESET Scholarship

### PHYSICS

**Question 1:** If the magnetic field in a plane electromagnetic wave is given by

$\vec{B} = 3 \times 10^{-8} \sin(1.6 \times 10^3 x + 48 \times 10^{10} t) T$ , Then what will be expression for electric field?

**Options:**

(a)  $\vec{E} = (3 \times 10^{-8} \sin(1.6 \times 10^3 x + 48 \times 10^{10} t)) \hat{i} V / m$

(b)  $\vec{E} = (60 \sin(1.6 \times 10^3 x + 48 \times 10^{10} t)) \hat{k} V / m$

(c)  $\vec{E} = (3 \times 10^{-8} (1.6 \times 10^3 x + 48 \times 10^{10} t)) \hat{j} V / m$

(d)  $\vec{E} = (3 \times 10^{-8} (1.6 \times 10^3 x + 48 \times 10^{10} t)) \hat{j} V / m$

**Question 2:** The time period of revolution of electron in its ground state orbit in a hydrogen atom is  $1.6 \times 10^{-16}$ . The frequency of revolution of the electron in its first excited state (in  $s^{-1}$ ) is

**Options:**

(a)  $6.2 \times 10^{15}$

(b)  $5.6 \times 10^{12}$

(c)  $7.8 \times 10^{14}$

(d)  $1.6 \times 10^{14}$

**Question 3:** Consider a circular coil of wire carrying current  $I$ , forming a magnetic dipole. The magnetic flux through an infinite plane that contains the circular coil and excluding the circular coil area is given by  $\phi_i$ . The magnetic flux through the area is given by  $\phi_0$ . Which of the following is correct?

**Options:**

(a)  $\phi_i > \phi_0$

(b)  $\phi_i < \phi_0$

(c)  $\phi_i = -\phi_0$

(d)  $\phi_i = \phi_0$

**Question 4:** Visible light of wavelength  $6000 \times 10^{-8}$  cm falls normally on a single slit and produces a diffraction pattern. If it is found that the second diffraction minimum is at  $60^\circ$  from the central maximum. if the first minimum is produced at  $\theta_1$ , the  $\theta_1$  is close to

**Options:**

(a)  $25^\circ$

(b)  $30^\circ$

(c)  $25^\circ$

(d)  $40^\circ$

**Question 5:** The radius of gyration of a uniform rod of length  $l$ , about an axis passing through a point  $\frac{1}{2}l$  away from the centre of the rod, and perpendicular to it, is

**Options:**

- (a)  $\sqrt{\frac{7}{48}}l$
- (b)  $\frac{1}{8}l$
- (c)  $\sqrt{\frac{3}{8}}l$
- (d)  $\frac{1}{4}l$

**Question 6:** A 60 HP electric motor lifts an elevator having a maximum total load capacity of 2000 kg. If the frictional force on the elevator is 4000 N, the speed of the elevator at full load is close to: (1 HP = 746 W,  $g = 10 \text{ ms}^{-2}$ )

**Options:**

- (a)  $1.5 \text{ ms}^{-1}$
- (b)  $1.9 \text{ ms}^{-1}$
- (c)  $2.0 \text{ ms}^{-1}$
- (d)  $1.7 \text{ ms}^{-1}$

**Question 7:** Two infinite planes each with uniform surface charge density  $+\sigma$  are kept in such a way that the angle between them is  $30^\circ$ . The electric field in the region shown between them is given by

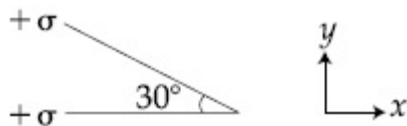

**Options:**

- (a)  $\frac{\sigma}{2\epsilon_0} \left[ (1 + \sqrt{3}) \hat{y} - \frac{\hat{x}}{2} \right]$
- (b)  $\frac{\sigma}{2\epsilon_0} \left[ \left( 1 - \frac{\sqrt{3}}{2} \right) \hat{y} - \frac{\hat{x}}{2} \right]$
- (c)  $\frac{\sigma}{2\epsilon_0} \left[ (1 + \sqrt{3}) \hat{y} + \frac{\hat{x}}{2} \right]$
- (d)  $\frac{\sigma}{\epsilon_0} \left[ \left( 1 + \frac{\sqrt{3}}{2} \right) \hat{y} + \frac{\hat{x}}{2} \right]$

**Question 8:** A satellite of mass  $m$  launched vertically upwards with an initial speed  $u$  from the surface of the earth. After it reaches height  $R$  ( $R =$  radius of the earth), it ejects a rocket of mass  $m/10$  so that subsequently the satellite moves in a circular orbit. The kinetic energy of the rocket is ( $G$  is the gravitational constant;  $M$  is the mass of the earth)

**Options:**

(a)  $\frac{m}{20} \left( u^2 + \frac{113 GM}{200 R} \right)$

(b)  $5m \left( u^2 - \frac{119 GM}{200 R} \right)$

(c)  $\frac{3m}{8} \left( u + \sqrt{\frac{5GM}{6M}} \right)^2$

(d)  $\frac{m}{20} \left( u - \sqrt{\frac{2GM}{3R}} \right)^2$

**Question 9:** A polarizer-analyser set is adjusted such that intensity of light coming out of the analyser is just 10% of the original intensity. Assuming that the polarizer. Analyser set does not absorb any light, the angle by which the analyser need to be rotated further to reduce the output intensity to be zero, is

**Options:**

(a)  $45^\circ$

(b)  $90^\circ$

(c)  $71.6^\circ$

(d)  $18.4^\circ$

**Question 10:** A long solenoid of radius R carries a time (t) - dependent current  $I(t) = I_0 t (1-t)$ . A ring of radius 2R is placed coaxially hear its middle. During the time interval  $0 \leq t \leq 1$ , the induced current ( $I_R$ ) and the induced EMF ( $V_R$ ) in the ring changes as

**Options:**

(a) Direction of  $I_R$  remains unchanged and  $V_R$  is zero at  $t = 0.25$

(b) At  $t = 0.5$  direction of  $I_R$  reverse and  $V_R$  is zero

(c) At  $t = 0.25$  direction of  $I_R$  reverses and  $V_R$  is maximum

(d) Direction of  $I_R$  remains unchanged and  $V_R$  is maximum at  $t = 0.5$

**Question 11:** Two moles of an ideal gas with  $\frac{C_p}{C_v} = \frac{5}{3}$  are mixed with 3 moles of another

ideal gas with  $\frac{C_p}{C_v} = \frac{4}{3}$ . The value of  $\frac{C_p}{C_v}$  for the mixture is

**Options:**

(a) 1.42

(b) 1.47

(c) 1.50

(d) 1.45

**Question 12:** Which of the following a reversible operation?

**Options:**

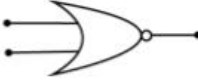
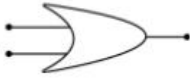
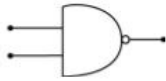
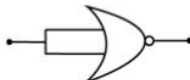
- (a) 
- (b) 
- (c) 
- (d) 

**Question 13:** Speed of a transverse wave on a straight wire (mass 6.0 g, length 60 cm and area of cross-section  $1.0 \text{ mm}^2$ ) is  $90 \text{ ms}^{-1}$ . If the Young's modulus of wire is  $16 \times 10^{11} \text{ Nm}^{-2}$ , the extension of wire over its natural length is

**Options:**

- (a) 0.02 mm  
 (b) 0.01 mm  
 (c) 0.03 mm  
 (d) 0.04 mm

**Question 14:** As shown in the figure, a bob a mass  $m$  is tied by a massless string whose other end portion is wound on a fly wheel (disc) of radius  $r$  and mass  $m$ . When released from rest the bob starts falling vertically. When it has covered a distance of  $h$ , the angular speed of the wheel will be

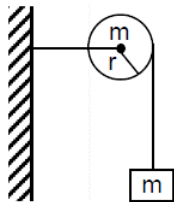

**Options:**

- (a)  $r \sqrt{\frac{3}{4gh}}$   
 (b)  $\frac{1}{r} \sqrt{\frac{3}{4gh}}$   
 (c)  $r \sqrt{\frac{3}{2gh}}$   
 (d)  $\frac{1}{r} \sqrt{\frac{4gh}{3}}$

**Question 15:** A LCR circuit behaves like a damped harmonic oscillator comparing it with a physical spring-mass damped oscillator having damping constant 'b', the correct equivalence would be

**Options:**

- (a)  $L \leftrightarrow \frac{1}{b}, C \leftrightarrow \frac{1}{m}, R \leftrightarrow \frac{1}{k}$
- (b)  $L \leftrightarrow k, C \leftrightarrow b, R \leftrightarrow m$
- (c)  $L \leftrightarrow m, C \leftrightarrow \frac{1}{k}, R \leftrightarrow b$
- (d)  $L \leftrightarrow m, C \leftrightarrow k, R \leftrightarrow b$

**Question 16:** Three point particles of masses 1.0 k.g., 1.5 kg and 2.5 kg are placed at three corners of a right  $\Delta$  of sides 4.0 cm, 3.0 cm and 5.0 cm as shown. The centre of mass of the system is at a pt.

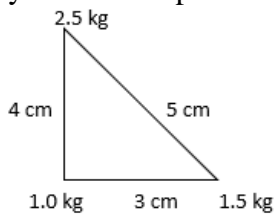

**Options:**

- (a) 0.6 cm right and 2.0 cm above 1 kg mass
- (b) 2.0 cm right and 0.9 cm above 1 kg mass
- (c) 0.9 cm right and 2.0 cm above 1 kg mass
- (d) 1.5 cm right and 1.2 cm above 1 kg mass

**Question 17:** The current  $I_1$  (in A) flowing through  $1\Omega$  resistor in the following circuit is

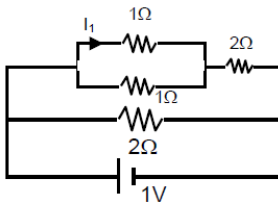

**Options:**

- (a) 0.2
- (b) 0.4
- (c) 0.5
- (d) 0.25

**Question 18:** If we need a magnification of 375 from a compound microscope of tube length 150 mm and an objective of focal length 5m, the focal length of the eye-piece, should be close to

**Options:**

- (a) 2 mm
- (b) 33 mm
- (c) 12 mm
- (d) 22 mm

**Question 19:** A litre of dry air at STP expands adiabatically to a volume of 3 litres. If  $\gamma = 1.40$ , the work done by air is:  $(3^{1.4} = 4.6555)$  [Take air to be an ideal gas]

**Options:**

- (a) 90.5 J
- (b) 48 J
- (c) 60.7 J
- (d) 100.8 J

**Question 20:** A parallel plate capacitor has plates of area  $A$  separated by distance ' $d$ ' between them. It is filled with a dielectric which has a dielectric constant that varies as  $k(x) = K(1 + \alpha x)$  where ' $x$ ' is the distance measured from one of the plates. If  $(\alpha d) \ll 1$ , the total capacitance of the system is best given by the expression

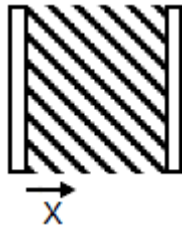

**Options:**

- (a)  $\frac{A\epsilon_0 K}{d} \left(1 + \frac{\alpha^2 d^2}{2}\right)$
- (b)  $\frac{A\epsilon K}{d} \left(1 + \frac{\alpha d}{2}\right)$
- (c)  $\frac{A\epsilon_0 K}{d} \left[1 + \left(\frac{\alpha d}{2}\right)^2\right]$
- (d)  $\frac{A\epsilon_0 K}{d} (1 + \alpha d)$

**Question 21:** A beam of electromagnetic radiation of intensity  $6.4 \times 10^{-5} \text{ w/cm}^2$  is comprised of wavelength,  $\lambda = 310 \text{ nm}$ . It falls normally on a metal (work function  $\Phi = 2\text{eV}$ ) of surface area  $1 \text{ cm}^2$ . If one in  $10^3$  photons ejects an electron, total number of electrons ejected in 1s is  $10^x$  ( $hc = 1240 \text{ eV nm}$ ,  $1 \text{ eV} = 1.6 \times 10^{-19} \text{ J}$ ), then  $x$  is \_\_\_\_\_.

**Question 22:** A particle ( $m = 1 \text{ kg}$ ) slides down a frictionless track (AOC) starting from rest at a point A (height 2m). After reaching C, the particle continues to move freely in air as a projectile. When it reaching its highest point P (height 1m), the kinetic energy of the particle (in J) is : (Figure drawn is schematic and not to scale; take  $g = 10 \text{ ms}^{-2}$ ) .....

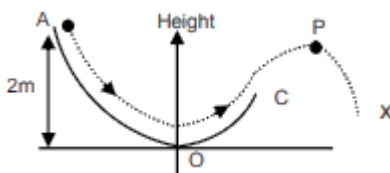

**Question 23:** A loop ABCDEFA of straight edges has six corner points A (0, 0, 0), B(5, 0, 0), C(5, 5, 0), D(0, 5, 0), E(0, 5, 5) and F(0, 0, 5). The magnetic field in this region is  $\vec{B} = (3\hat{i} + 4\hat{k})T$ . The quantity of flux through the loop ABCDEFA (in Wb) is \_\_\_\_\_.

**Question 24:** A non-isotropic solid metal cube has coefficients of linear expansion as:  $5 \times 10^{-5} / ^\circ\text{C}$  along the x-axis and  $5 \times 10^{-6} / ^\circ\text{C}$  along the y and the z-axis. If coefficient of volume expansion of the solid  $C \times 10^{-6} / ^\circ\text{C}$  then the value of C is \_\_\_\_

**Question 25:** A Carnot engine operates between two reservoirs of temperature 900 K and 300 K. The engine performs 1200 J of work per cycle. The heat energy (in J) delivered by the engine to the low temperature reservoir, in a cycle, is

## CHEMISTRY

**Question 26:** Amongst the following statements, that which was not proposed by Dalton was  
**Options:**

- (a) when gases combine or reproduced in a chemical reaction, they do so in a simple ratio by volume provided all gases are at the same T & P.
- (b) matter consists of indivisible atoms
- (c) chemical reactions involve reorganization of atoms. These are neither created nor destroyed in a chemical reaction
- (d) all the atoms of a given element have identical properties including identical mass. Atoms of different elements differ in mass

**Question 27:** A solution of m-chloroaniline, m-chlorophenol and m-chlorobenzoic acid in ethyl acetate was treated initially with a saturated solution of  $\text{NaHCO}_3$  to give fraction A. The left-over organic phase was extracted with dilute  $\text{NaOH}$  solution to give fraction B. The final organic layer was labelled as fraction C. Fractions A, B and C contain respectively

**Options:**

- (a) m-chlorobenzoic acid, m-chlorophenol and m-chloroaniline
- (b) m-chlorophenol, m-chlorobenzoic acid and m-chloroaniline
- (c) m-chloroaniline, m-chlorobenzoic acid and m-chlorophenol
- (d) m-chlorobenzoic acid, m-chloroaniline and m-chlorophenol

**Question 28:** The atomic radius of Ag is closest to

**Options:**

- (a) Au
- (b) Hg
- (c) Ni
- (d) Cu

**Question 29:** Consider the following reaction:

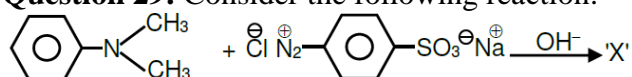

The product X is

**Options:**

- (a) in laboratory test for phenols
- (b) Used in protein estimation as an alternative to ninhydrin
- (c) in acid base titration as an indicator
- (d) as food grade colourant



**Question 30:** 1-methyl-ethylene oxide when treated with an excess of HBr produces

**Options:**

(a)

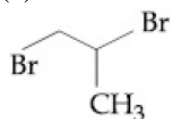

(b)

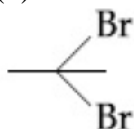

(c)

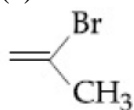

(d)

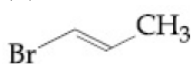

**Question 31:** Given that the standard potentials ( $E^\circ$ ) of  $\text{Cu}^{2+}/\text{Cu}$  and  $\text{Cu}^+/\text{Cu}$  are 0.34 V and 0.522 V respectively, the  $E^\circ$  of  $\text{Cu}^{2+}/\text{Cu}^+$  is

**Options:**

(a) +0.158 V

(b) -0.182 V

(c) 0.182 V

(d) -0.158 V

**Question 32:** The increasing order of  $\text{pK}_b$  for the following compounds will be

(A)  $\text{NH}_2\text{-CH=NH}$ ,

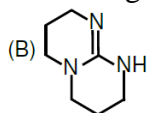

(C)  $\text{CH}_3\text{-NH-CH}_3$

**Options:**

(a) (A) < (B) < (C)

(b) (B) < (C) < (A)

(c) (B) < (A) < (C)

(d) (C) < (A) < (B)

**Question 33:** What is the product of following reaction?

Hex-3-ynal  $\xrightarrow{\text{(i) NaBH}_4}$  ?

(ii)  $\text{PBr}_3$

(iii)  $\text{Mg/ether}$

(iv)  $\text{CO}_2/\text{H}_3\text{O}^+$

**Options:**

(a)

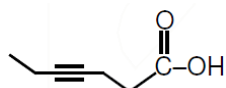

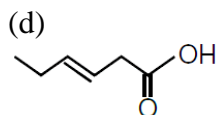
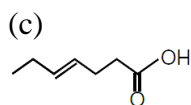
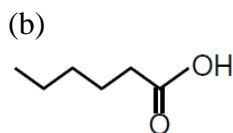

**Question 34:** At 35°C, the vapour pressure of CS<sub>2</sub> is 512 mm Hg and that of acetone is 344 mm Hg. A solution of CS<sub>2</sub> in acetone has a total vapour pressure of 600 mm Hg. The false statement amongst the following is

**Options:**

- (a) heat must be absorbed in order to produce the solution at 35°C
- (b) Raoult's law is not obeyed by this system
- (c) a mixture of 100 ml CS<sub>2</sub> and 100 ml acetone has a volume of <200 ml
- (d) CS<sub>2</sub> and acetone are less attracted to each other than to themselves

**Question 35:** Oxidation number of potassium in K<sub>2</sub>O, K<sub>2</sub>O<sub>2</sub> and KO<sub>2</sub>, respectively is

**Options:**

- (a) +1, +2 and +4
- (b) +1, +4 and +2
- (c) +1, +1 and +1
- (d) +2, +1 and +½

**Question 36:** The dipole moments of CCl<sub>4</sub>, CHCl<sub>3</sub> and CH<sub>4</sub> are in order

**Options:**

- (a) CH<sub>4</sub> < CCl<sub>4</sub> < CHCl<sub>3</sub>
- (b) CCl<sub>4</sub> < CH<sub>4</sub> < CHCl<sub>3</sub>
- (c) CHCl<sub>3</sub> < CH<sub>4</sub> = CCl<sub>4</sub>
- (d) CH<sub>4</sub> = CCl<sub>4</sub> < CHCl<sub>3</sub>

**Question 37:** In comparison to the Zeolite process for the removal of permanent hardness, the synthetic resins method is

**Options:**

- (a) more efficient as it can exchange both cations as well as anions
- (b) less efficient as it exchanges only anions
- (c) more efficient as it can exchange only cations
- (d) less efficient as the reverse cannot be regenerated

**Question 38:** The theory that can completely/properly explain the nature of bonding in [Ni(CO)<sub>4</sub>] is

**Options:**

- (a) Crystal field theory
- (b) Werner's theory
- (c) Molecular orbital theory

(d) Valence bond theory

**Question 39:** The IUPAC name of the complex  $[\text{Pt}(\text{NH}_3)_2\text{Cl}(\text{CH}_3\text{NH}_2)]$  is

**Options:**

- (a) Bisammine(methanamine)chloridoplatinum(II)chloride
- (b) Diammine(methanamine)chloridoplatinum(II)chloride
- (c) Diamminechlorido(methanamine)platinum(II)chloride
- (d) Diamminechlorido(amminomethane)platinum(II)chloride

**Question 40:** The number of orbitals associated with quantum numbers  $n = 5$ ,  $m_s = +\frac{1}{2}$  is

**Options:**

- (a) 11
- (b) 25
- (c) 50
- (d) 15

**Question 41:** The electron gain enthalpy (in kJ/mol) of fluorine, chlorine, bromine, iodine respectively is

**Options:**

- (a) -296, -325, -333, -349
- (b) -333, -349, -325, -296
- (c) -349, -333, -325, -296
- (d) -333, -325, -349, -296

**Question 42:** Match the following:

**Column-I**

(i) Riboflavin

(ii) Thiamine

(iii) Pyridoxine

(iv) Ascorbic Acid

**Column-II**

(a) Beriberi

(b) Scurvy

(c) Cheilosis

(d) Convulsions

**Options:**

- (a) (i)-(c), (ii)-(a), (iii)-(d), (iv)-(b)
- (b) (i)-(c), (ii)-(d), (iii)-(a), (iv)-(b)
- (c) (i)-(a), (ii)-(d), (iii)-(c), (iv)-(b)
- (d) (i)-(d), (ii)-(b), (iii)-(a), (iv)-(c)

**Question 43:** The purest form of commercial iron is

**Options:**

- (a) cast iron
- (b) scrap iron and pig iron
- (c) pig iron
- (d) wrought iron

**Question 44:** The relative strength of interionic/intermolecular forces is decreasing order is

**Options:**

- (a) dipole-dipole > ion-dipole > ion-ion

- (b) ion-ion > ion-dipole > dipole-dipole  
 (c) ion-dipole > dipole-dipole > ion-ion  
 (d) ion-dipole > ion-ion > dipole-dipole

**Question 45:** Consider the following reactions:

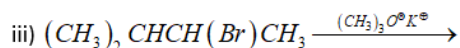
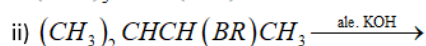
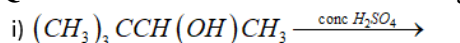

iv)

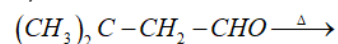

Which of the reaction(s) will not produce Saytzeff product?

**Options:**

- (a) (i) and (iv)  
 (b) (i), (iii) and (iv)  
 (c) (iv) only  
 (d) (iii) only

**Question 46:** For the reaction  $A_{(l)} \rightarrow 2B_{(g)}$   $\Delta U = 2.1 \text{ kcal}$ ,  $\Delta S = 20 \text{ cal K}^{-1}$  at 300 K. Hence  $\Delta G$  in kcal is.

**Question 47:** During the nuclear explosion one of the products of  $^{90}\text{Sr}$  with half life of 6.93 years. If 1  $\mu\text{g}$  of  $^{90}\text{Sr}$  was absorbed in the bones of a newly born baby in place of Ca, how much time, in years, is required to reduce it by 90% if it is not lost metabolically \_\_\_\_\_.

**Question 48:** The number of chiral carbons in chloramphenicol is \_\_\_\_\_.

**Question 49:** Two solutions A and B, each of 100 L was made by dissolving 4g of NaOH and 9.8 g of  $H_2SO_4$  in water, respectively. The pH of the resultant solution obtained from mixing 40 L of solution A and 10 L of solution B is \_\_\_\_\_.

**Question 50:** Chlorine reacts with hot and concentrated NaOH and produces compounds (X) and (Y). Compound (X) gives white precipitate with silver nitrate solution. The average bond order between Cl and O atoms in (Y) is \_\_\_\_\_.

## MATHEMATICS

**Question 51:** Let P be a plane passing through the points (2, 1, 0), (4, 1, 1) and (5, 0, 1) and R be any point (2, 1, 6). Then the image of R in the plane P is

**Options:**

- (a) (6, 5, -2)  
 (b) (4, 3, 2)  
 (c) (6, 5, 2)  
 (d) (3, 4, -2)

**Question 52:** If the system of linear equations

$$2x + 2ay + az = 0$$

$$2x + 3by + bz = 0$$

$$2x + 4cy + cz = 0$$

where  $a, b, c \in \mathbb{R}$  are non-zero and distinct; has non-zero solution then

**Options:**

(a)  $a, b, c$  are in A.P.

(b)  $\frac{1}{a}, \frac{1}{b}, \frac{1}{c}$  are in A.P.

(c)  $a + b + c = 0$

(d)  $a, b, c$  are in G.P.

**Question 53:** The greatest positive integer  $k$ , for which  $49^k + 1$  is a factor of the sum  $49^{125} + 49^{124} + \dots + 49^2 + 49 + 1$ , is

**Options:**

(a) 32

(b) 63

(c) 65

(d) 60

**Question 54:** A vector  $\vec{a} = \alpha \hat{i} + 2\hat{j} + \beta \hat{k}$  ( $\alpha, \beta \in \mathbb{R}$ ) lies in the plane of the vectors,  $\vec{b} = \hat{i} + \hat{j}$  and  $\vec{c} = \hat{i} - \hat{j} + \hat{k}$ . If  $\vec{a}$  bisects the angle between  $\vec{b}$  and  $\vec{c}$ , then

**Options:**

(a)  $\vec{a} \cdot \hat{k} + 4 = 0$

(b)  $\vec{a} \cdot \hat{k} + 2 = 0$

(c)  $\vec{a} \cdot \hat{i} + 1 = 0$

(d)  $\vec{a} \cdot \hat{i} + 3 = 0$

**Question 55:** If  $y(\alpha) = \sqrt{2 \left( \frac{\tan \alpha + \cot \alpha}{1 + \tan^2 \alpha} \right) + \frac{1}{\sin^2 \alpha}}$ ,  $\alpha \in \left( \frac{3\pi}{4}, \pi \right)$  then  $\frac{dy}{d\alpha}$  at  $\alpha = \frac{5\pi}{6}$  is

**Options:**

(a) 4

(b)  $\frac{4}{3}$

(c)  $-\frac{1}{4}$

(d) -4

**Question 56:** Let  $\alpha$  be a root of equation  $x^2 + x + 1 = 0$  and the matrix  $A = \frac{1}{\sqrt{3}} \begin{bmatrix} 1 & 1 & 1 \\ 1 & a & a^2 \\ 1 & a^2 & a^4 \end{bmatrix}$

then the matrix  $A^{31}$  is

**Options:**

- (a)  $A^3$
- (b)  $A^2$
- (c)  $I_3$
- (d)  $A$

**Question 57:** If the distance between the foci of an ellipse is 6 and the distance between its directrices is 12, then the length of its latus rectum is

**Options:**

- (a)  $\sqrt{3}$
- (b)  $3\sqrt{2}$
- (c)  $\frac{3}{\sqrt{2}}$
- (d)  $2\sqrt{3}$

**Question 58:** If  $y = mx + 4$  is a tangent to both the parabolas.  $y^2 = 4x$  and  $x^2 = 2by$ , then  $b$  is equal to

**Options:**

- (a) -64
- (b) -32
- (c) -128
- (d) 128

**Question 59:** Let  $y = f(x)$  is the solution of the differential equation  $e^y \left( \frac{dy}{dx} = 1 \right) = e^x$  such

that  $y(0) = 0$ , then  $y(1)$  is equal to

**Options:**

- (a)  $2e$
- (b)  $1 + \log_e 2$
- (c)  $\log_e 2$
- (d)  $2 + \log_e 2$

**Question 60:** Total number of 6 digit numbers in which only and all the five digits 1, 3, 5, 7 and 9 appears is

**Options:**

- (a)  $5^6$

- (b)  $\frac{1}{2} (6!)$
- (c)  $6!$
- (d)  $\frac{5}{2} (6!)$

**Question 61:** Five numbers are in A.P., whose sum is 25 and product is 2520. If one of these five numbers is  $-\frac{1}{2}$ , then the greatest number amongst them is

**Options:**

- (a)  $\frac{21}{2}$
- (b) 16
- (c) 27
- (d) 7

**Question 62:** The logical statement  $(p \Rightarrow q) \wedge (q \Rightarrow \sim p)$  is equivalent to

**Options:**

- (a)  $p$
- (b)  $q$
- (c)  $\sim p$
- (d)  $\sim q$

**Question 63:** Let  $\alpha$  and  $\beta$  be two real roots of the equation  $(K + 1) \tan^2 x - \sqrt{2} \cdot \lambda \tan x = (1 - K)$ , where  $K \neq 1$  and  $\lambda$  are real numbers. If  $\tan^2(\alpha + \beta) = 50$ , then value of  $\lambda$  is

**Options:**

- (a)  $10\sqrt{2}$
- (b)  $5\sqrt{2}$
- (c) 10
- (d) 5

**Question 64:** If  $g(x) = x^2 + x - 1$  and  $(g \circ f)(x) = 4x^2 - 10x + 5$ , then  $\left(\frac{5}{4}\right)$  is equal to

**Options:**

- (a)  $\frac{1}{2}$
- (b)  $-\frac{3}{2}$
- (c)  $-\frac{1}{2}$
- (d)  $\frac{3}{2}$

**Question 65:** If  $f(a+b+1-x) = f(x)$ , for all  $x$ , where  $a$  and  $b$  are fixed positive real

numbers, then  $\frac{1}{a+b} \int x(f(x) + f(x+1)) dx$  is equal to

**Options:**

(a)  $\int_{a+1}^{b+1} f(x+1) dx$

(b)  $\int_{b-1}^{a-1} f(x+1) dx$

(c)  $\int_{a-1}^{b-1} f(x) dx$

(d)  $\int_{a+1}^{b+1} f(x) dx$

**Question 66:** If  $\operatorname{Re}\left(\frac{z-1}{2z+i}\right) = 1$ , where  $z = x + iy$ , then the point  $(x, y)$  lies on a

**Options:**

(a) Straight line whose slope is  $-\frac{2}{3}$

(b) Straight line whose slope is  $\frac{3}{2}$

(c) circle whose diameter is  $\sqrt{5}/2$

(d) circle whose centre is at  $(-\frac{1}{2}, -\frac{3}{2})$

**Question 67:** The area of the region enclosed by the circle  $x^2 + y^2 = 2$  which is not common to the region bounded by the parabola  $y^2 = x$  and the straight line  $y = x$ , is

**Options:**

(a)  $\frac{1}{3}(6\pi - 1)$

(b)  $\frac{1}{3}(12\pi - 1)$

(c)  $\frac{1}{6}(12\pi - 1)$

(d)  $\frac{1}{6}(24\pi - 1)$

**Question 68:** An unbiased coin is tossed 5 times. Suppose that a variable  $X$  is assigned the value  $k$  when  $k$  consecutive heads are obtained for  $k = 3, 4, 5$ , otherwise  $X$  takes the value  $-1$ .

Then the expected value of  $X$  is

**Options:**

(a)  $\frac{3}{16}$

(b)  $-\frac{1}{8}$



(c)  $-\frac{3}{16}$

(d)  $\frac{1}{8}$

**Question 69:** Let the function  $f : [-7, 0] \rightarrow R$  be continuous on  $[-7, 0]$  and differentiable on  $(-7, 0)$ . If  $f(-7) = -3$  and  $f'(x) \leq 2$ , for all  $x \in (-7, 0)$ , then for all such functions  $f$ ,  $f(-1) + f(0)$  lies in the interval

**Options:**

(a)  $(-6, 20)$

(b)  $[-\infty, 20]$

(c)  $(-\infty, 11]$

(d)  $[-3, 11)$

**Question 70:** Let  $x^k + y^k = a^k$ , ( $a, k > 0$ ) and  $\frac{dy}{dx} + \left(\frac{y}{x}\right)^{\frac{1}{3}} = 0$ , then k is

**Options:**

(a)  $\frac{4}{3}$

(b)  $\frac{2}{3}$

(c)  $\frac{1}{3}$

(d)  $\frac{3}{2}$

**Question 71:** Let S be the set of points, where the function  $f(x) = |2 - |x - 3||$ ,  $\in R$  is not differentiable, then  $\sum_{x \in y} f(f(x))$  is equal to

**Question 72:** If the variance of the first n natural numbers is 10 and the variance of the first m even natural numbers is 16, then m + n is equal to \_\_\_\_\_

**Question 73:** Let A(1, 0), B(6, 2) and  $C\left(\frac{3}{2}, 6\right)$  be the vertices of a triangle ABC. If P is a point inside the  $\Delta ABC$  such that the triangles APC, APB and BPC have equal areas, then the length of the line segment PQ, where Q is the point  $\left(-\frac{7}{6}, -\frac{1}{3}\right)$  is \_\_\_\_\_.

**Question 74:**  $\lim_{x \rightarrow 2} \frac{3^x + 3^{x-1} - 12}{3^{\frac{x}{2}} - 3^{1-x}}$  is equal to

**Question 75:** If the sum of the coefficients of all even powers of  $x$  in the product  $(1 + x + x^2 + \dots + x^{2n})(1 - x + x^2 - x^3 + \dots + x^{2n})$  is 61, then  $n$  is equal to \_\_\_\_\_

## Answer Key

<b>1.</b> (d)	<b>2.</b> (c)	<b>3.</b> (c)	<b>4.</b> (a)	<b>5.</b> (a)	<b>6.</b> (b)	<b>7.</b> (b)	<b>8.</b> (b)	<b>9.</b> (d)	<b>10.</b> (b)
11. (a)	12. (d)	13. (c)	14. (d)	15. (c)	16. (c)	17. (a)	18. (d)	19. (a)	20. (b)
<b>21.</b> (11.00)	<b>22.</b> (10.00)	<b>23.</b> (175.00)	<b>24.</b> (60.00)	<b>25.</b> (600.00)	<b>26.</b> (a)	<b>27.</b> (a)	<b>28.</b> (a)	<b>29.</b> (c)	<b>30.</b> (a)
<b>31.</b> (a)	<b>32.</b> (c)	<b>33.</b> (a)	<b>34.</b> (c)	<b>35.</b> (c)	<b>36.</b> (d)	<b>37.</b> (a)	<b>38.</b> (c)	<b>39.</b> (c)	<b>40.</b> (b)
<b>41.</b> (b)	<b>42.</b> (a)	<b>43.</b> (d)	<b>44.</b> (b)	<b>45.</b> (d)	<b>46.</b> – (2.7)	<b>47.</b> (23.03)	<b>48.</b> (2.00)	<b>49.</b> (10.5)	<b>50.</b> (1.67)
<b>51.</b> (a)	<b>52.</b> (b)	<b>53.</b> (b)	<b>54.</b> (b)	<b>55.</b> (a)	<b>56.</b> (a)	<b>57.</b> (b)	<b>58.</b> (c)	<b>59.</b> (b)	<b>60.</b> (d)
<b>61.</b> (b)	<b>62.</b> (c)	<b>63.</b> (c)	<b>64.</b> (c)	<b>65.</b> (b)	<b>66.</b> (c)	<b>67.</b> (c)	<b>68.</b> (d)	<b>69.</b> (b)	<b>70.</b> (b)
<b>71.</b> (3.00)	<b>72.</b> (18.00)	<b>73.</b> (5.00)	<b>74.</b> (36.00)	<b>75.</b> (30.00)					

# SOLUTIONS

## PHYSICS

### **Solution 1:**

Expression for Electric field

$$\frac{E_0}{B_0} = C \text{ (Speed of light in vacuum)}$$

$$E_0 = B_0 C = 3 \times 10^{-8} \times 3 \times 10^8 \\ = 9 \text{ N/C}$$

$$\text{So, } E = 9 \sin(1.6 \times 10^3 x + 48 \times 10^{10} t)$$

### **Solution 2:**

The frequency of revolution of the electron in its first excited state

$$T \propto \frac{r}{v} \propto \frac{n^2}{z} \times \frac{n}{z} \propto \frac{n^3}{z^2}$$

$$\frac{T_1}{T_2} = \frac{n_1^3}{n_2^3} = \frac{1}{8}$$

$$T_2 = 8T_1$$

$$= 8 \times 1.6 \times 10^{-16} = 12.8 \times 10^{-16}$$

$$f_2 = \frac{1}{12.8 \times 10^{-16}} \approx 7.8 \times 10^{14}$$

### **Solution 3:**

As magnetic field lines always form a closed loop, hence every magnetic field line creating magnetic flux in the inner region must be passing through the outer region. The magnetic flux through the area is given by  $\phi_0$ . Since flux in two regions are in opposite direction ,

$$\therefore \phi_i = -\phi_0$$

### **Solution 4:**

For 2nd minima

$$d \sin \theta = 2\lambda$$

$$\sin \theta = \frac{\sqrt{3}}{2} \text{ (given)}$$

$$\Rightarrow \frac{\lambda}{d} = \frac{\sqrt{3}}{4} \dots (i)$$

So for 1<sup>st</sup> minima is

$$d \sin \theta = \lambda$$

$$\sin \theta = \frac{\lambda}{d} = \frac{\sqrt{3}}{4} \text{ (from equation (i))}$$

$$\theta = 25.65^\circ$$

$$\theta \approx 25^\circ$$

**Solution 5:**

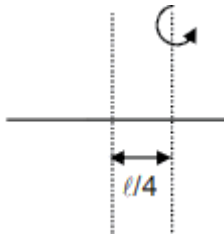

$$\frac{Ml^2}{12} + M\left(\frac{l}{4}\right)^2 = MK^2$$

$$K = \sqrt{\frac{7}{48}} l$$

**Solution 6:**

the speed of the elevator at full load is

$$4000 \times V + mg \times V = P$$

$$\frac{60 \times 746}{4000 + 20000} = V$$

$$V = 1.86 \text{ m/s} \approx 1.9 \text{ m/s}$$

**Solution 7:**

The electric field in the region shown

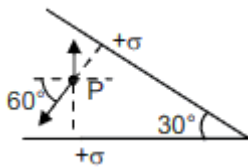

$$\vec{E} = \frac{\sigma}{2\epsilon_0} \cos 60^\circ (-\hat{x}) + \left[ \frac{\sigma}{2\epsilon_0} - \frac{\sigma}{2\epsilon_0} \sin 60^\circ \right] (\hat{y})$$

$$\vec{E} = \frac{\sigma}{2\epsilon_0} \left[ \left(1 - \frac{\sqrt{3}}{2}\right) \hat{y} - \frac{1}{2} \hat{x} \right]$$

**Solution 8:**

The kinetic energy of the rocket is

$$\frac{-GM_e M}{R} + \frac{1}{2} Mu^2 = \frac{-GM_e M}{2R} + \frac{1}{2} MV^2$$

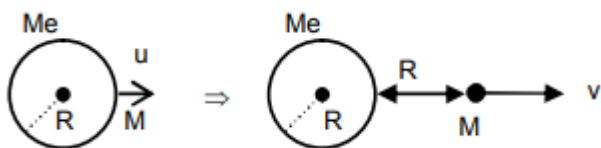

$$v = \sqrt{u^2 - \frac{GM_e}{R}}$$

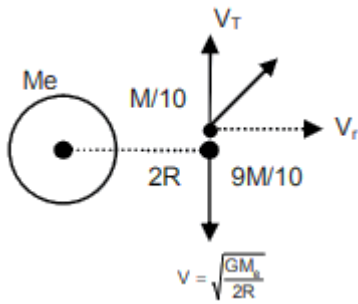

$V_T$  → Transverse velocity of rocket

$V_R$  → Radial velocity of rocket

$$\frac{M}{10} V_T = \frac{9M}{10} \sqrt{\frac{GM_e}{2R}}$$

$$\frac{M}{10} V_r = M \sqrt{u^2 - \frac{GM_e}{R}}$$

$$\begin{aligned} \text{Kinetic energy} &= \frac{1}{2} \frac{M}{10} (V_T^2 + V_r^2) = \frac{M}{20} \left( 81 \frac{GM_e}{2R} + 100u^2 - 100 \frac{GM_e}{R} \right) \\ &= 5M \left( u^2 - \frac{119GM_e}{200R} \right) \end{aligned}$$

### Solution 9:

Analyser set does not absorb any light, the angle by which the analyser need to be rotated further to reduce the output intensity to be zero, is

$$I = I_0 \cos^2 \theta$$

$$\cos \theta = \frac{1}{\sqrt{10}} = 0.31 < \frac{1}{\sqrt{2}} \text{ which is } 0.707$$

So  $\theta > 45^\circ$  and  $90 - \theta < 45^\circ$  so any one option is correct  
i.e.,  $18.4^\circ$

angle rotated should be  $= 90^\circ - 71.6^\circ = 18.4^\circ$

### Solution 10:

$$I = I_0 t - I_0 t^2$$

$$\phi = BA$$

$$\phi = \mu_0 n I A$$

$$V_R = - \frac{d\phi}{dt} = -\mu_0 n A I_0 (1 - 2t)$$

$$V_R = 0 \text{ at } t = \frac{1}{2}$$

$$\text{and } I_R = \frac{V_R}{\text{Resistance of loop}}$$

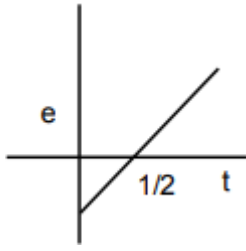

**Solution 11:**

The value of  $\frac{C_p}{C_v}$  for the mixture is

$$\gamma_{\text{mixture}} = \frac{n_1 C_{P_1} + n_2 C_{P_2}}{n_1 C_{V_1} + n_2 C_{V_2}} = \frac{n_1 \frac{\gamma_1 R}{\gamma_1 - 1} + n_2 \frac{\gamma_2 R}{\gamma_2 - 1}}{\frac{n_1 R}{\gamma_1 - 1} + \frac{n_2 R}{\gamma_2 - 1}}$$

On rearranging we get

$$\frac{n_1 + n_2}{\gamma_{\text{mix}} - 1} = \frac{n_1}{\gamma_1 - 1} + \frac{n_2}{\gamma_2 - 1}; \quad \frac{5}{\gamma_{\text{mix}} - 1} = \frac{3}{1/3} + \frac{2}{2/3}$$

$$\frac{5}{\gamma_{\text{mix}} - 1} = 9 + 3 = 12 \Rightarrow \gamma_{\text{mixture}} = \frac{17}{12} = 1 + \frac{5}{12}; \quad \gamma_{\text{mix}} = 1.42$$

**Solution 12:**

NOT gate

**Solution 13:**

$$v = \sqrt{\frac{T}{\mu}}$$

$$\frac{\mu v^2}{A} = Y \frac{\Delta l}{l}$$

$$\Delta l = \frac{\mu V^2 l}{AY}$$

$$\Delta l = 0.03 \text{ mm}$$

**Solution 14:**

When it has covered a distance of h, the angular speed of the wheel will be

$$mgh = \frac{1}{2} mv^2 + \frac{1}{2} I \omega^2$$

$$v = \omega R \text{ (no Slipping)}$$

$$mgh = \frac{1}{2} m \omega^2 R^2 + \frac{1}{2} \frac{mR^2}{2} \omega^2$$

$$\omega = \sqrt{\frac{4gh}{3R^2}} = \frac{1}{R} \sqrt{\frac{4gh}{3}}$$

**Solution 15:**

In damped oscillation

$$ma + bv + kx = 0$$

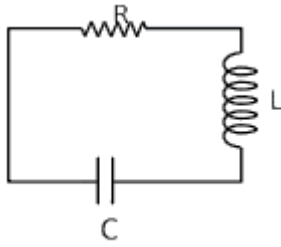

$$m \frac{d^2x}{dt^2} + b \frac{dx}{dt} + kx = 0 \dots(i)$$

$$L \frac{d^2q}{dt^2} + R \frac{dq}{dt} + \frac{1}{c} \cdot q = 0 \dots(ii)$$

Comparing (i) and (ii)

$$m = L, b = R, k = \frac{1}{c}$$

**Solution 16:**

The centre of mass of the system is at a pt.

Take 1kg mass at origin

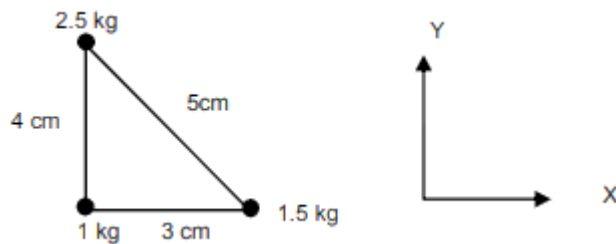

$$X_{cm} = \frac{1 \times 0 + 1.5 \times 3 + 2.5 \times 0}{5} = 0.9 \text{ cm}$$

$$Y_{cm} = \frac{1 \times 0 + 1.5 \times 0 + 2.5 \times 4}{5} = 2 \text{ cm}$$

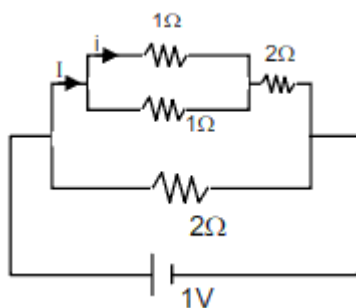
**Solution 17:**

$$I = \frac{1}{2.5} = 0.4 \text{ A}$$

$$i = \frac{I}{2} = 0.2 \text{ A}$$



**Solution 18:****Case-I**

If final image is at least distance of clear vision

$$M.P. = \frac{L}{f_0} \left( 1 + \frac{D}{f_e} \right); 375 = \frac{150}{5} \left[ 1 + \frac{25}{f_e} \right]$$

$$\frac{375}{30} = 1 + \frac{25}{f_e}$$

$$f_e = \frac{750}{345} = 2.17 \text{ cm}; f_e \approx 22 \text{ mm}$$

**Case-II**

If final image is at infinity

$$M.P. = \frac{L}{f_0} \left( \frac{D}{f_e} \right) = 375$$

$$f_e = 22 \text{ mm}$$

**Solution 19:**

$$P_1 V_1^\gamma = P_2 V_2^\gamma$$

$$P_2 = P_1 \left[ \frac{V_1}{V_2} \right]^\gamma$$

$$= 1 \text{ atm} \left( \frac{1}{3} \right)^{1.4}$$

$$\text{Now work done} = \frac{P_1 V_1 - P_2 V_2}{\gamma - 1} = 88.7 \text{ J}$$

Closest answer is 90.5 J

**Solution 20:**

$$\text{Capacitance of element } C' = \frac{K(1 + \alpha x) \epsilon_0 A}{dx}$$

$$\sum \frac{1}{C'} = \int_0^d \frac{dx}{K \epsilon_0 A (1 + \alpha x)}$$

$$\frac{1}{C} = \frac{1}{K \epsilon_0 A \alpha} \ln(1 + \alpha d)$$

Given  $\alpha d \ll 1$

$$\frac{1}{C} = \frac{d}{K \epsilon_0 A} \left( 1 - \frac{\alpha d}{2} \right)$$

$$C = \frac{K \epsilon_0 A}{d} \left( 1 + \frac{\alpha d}{2} \right)$$

**Solution 21:**

total number of electrons ejected in 1s is

Energy of photon.  $E = \frac{1240}{310} = 4eV > 2eV$  (so photoelectric effect will take place)

$$= 4 \times 1.6 \times 10^{-19} = 6.4 \times 10^{-19} \text{ Joule}$$

No. of photons falling per second

$$= \frac{6.4 \times 10^{-5} \times 1}{6.4 \times 10^{-19}} = 10^{14}$$

No. of photoelectron emitted per second

$$= \frac{10^{14}}{10^3} = 10^{11}$$

**Solution 22:**

When it reaching its highest point P (height 1m), the kinetic energy of the particle (in J) is

$$KE = PE_1 - PE_2 = mgh_1 - mgh_2$$

$$= 1 \times 10 \times 2 - 1 \times 10 \times 1 = 10 \text{ J}$$

**Solution 23:**

The quantity of flux through the loop ABCDEFA(in Wb) is

$$\phi = \vec{B} \cdot \vec{A} = (3\hat{i} + 4\hat{k}) \cdot (25\hat{i} + 25\hat{k})$$

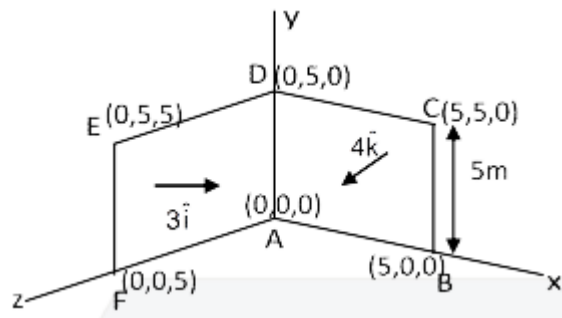

$$\phi = (3 \times 25) + (4 \times 25) = 175 \text{ weber}$$

**Solution 24:**

If coefficient of volume expansion of the solid  $C \times 10^{-6}/^\circ\text{C}$  then the value of C is \_\_\_\_

$$V = 2\alpha_2 + \alpha_1$$

$$= 10 \times 10^{-6} + 5 \times 10^{-5}$$

$$= 60 \times 10^{-6} / ^\circ\text{C}$$

**Solution 25:**

The heat energy (in J) delivered by the engine to the low temperature reservoir, in a cycle, is

$$\eta = \frac{W}{Q_h} = 1 - \frac{300}{900} = \frac{2}{3}$$

$$Q_h = \frac{3}{2} W = 1800 \text{ J}$$

$$Q_L = Q_h - W = 600 \text{ J}$$

## CHEMISTRY

**Solution 26:** Gay Lussac's law: When gases combine or reproduced in a chemical reaction, they do so in a simple ratio by volume provided all gases are at the same T and P.

**Solution 27:**

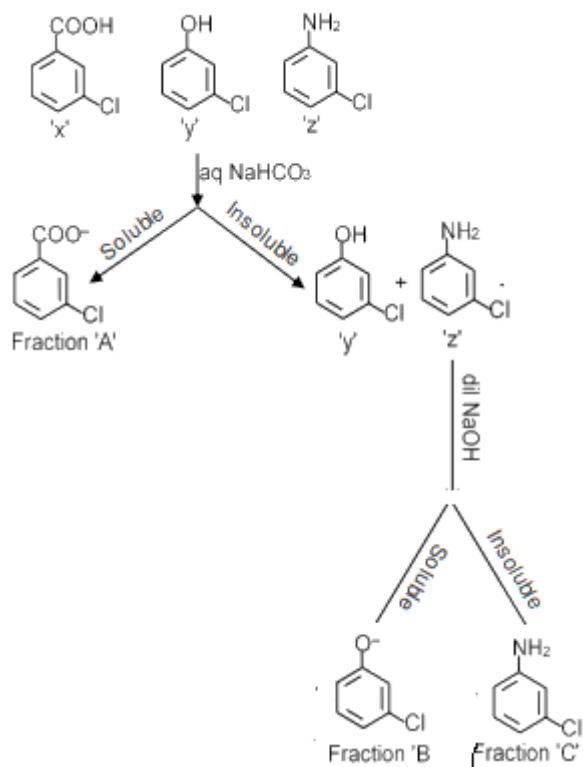

**Solution 28:** Gold (Au) atomic radius is closest of silver (Ag).

**Solution 29:**

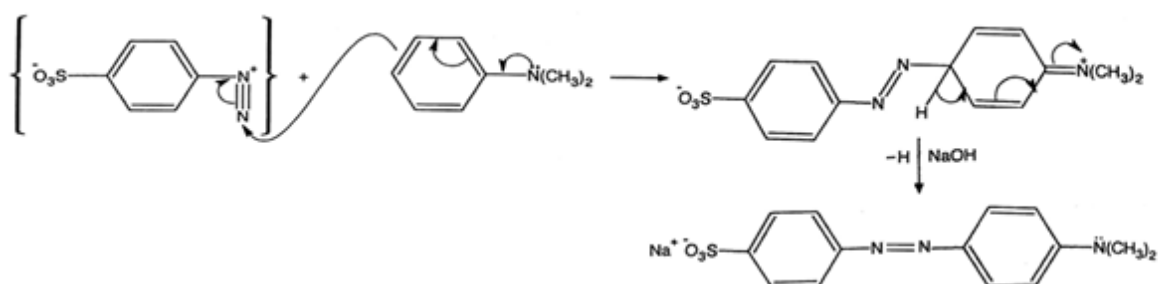

In acid base titration, Methyl orange is used as an indicator.

**Solution 30:**

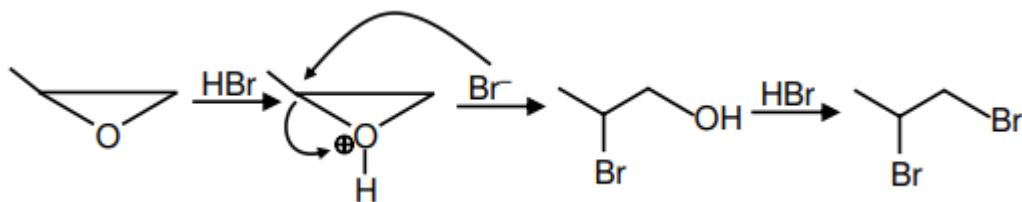

**Solution 31:**

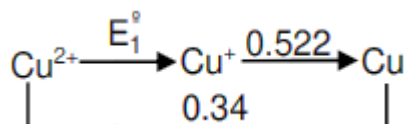

$$E_1^0 + 1 \times 0.522 = 2 \times 0.34$$

$$E_1 = 0.68 - 0.522 \Rightarrow E_1 = 0.158 \text{ V}$$

**Solution 32:**

(A)  $\text{NH}_2\text{-CH=NH}$ ,

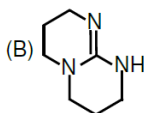

(C)  $\text{CH}_3\text{-NH-CH}_3$

Guanidine (B), the conjugate acid which is resonance stabilised and in aliphatic amine, the structure (C) 'N' is  $\text{sp}^3$  whereas in (A) the 'N' is  $\text{sp}^2$

**Solution 33:**

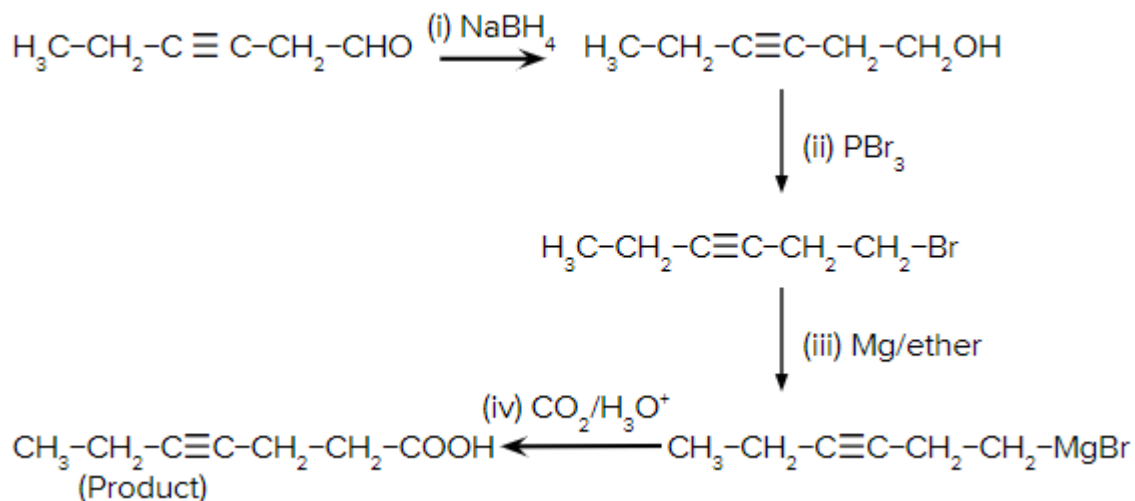

**Solution 34:** It shows positive deviation from Raoult's Law.

**Solution 35:**

In  $\text{K}_2\text{O}$ , potassium combines with oxide ion ( $\text{O}^{2-}$ )

Oxidation state of K is +1, of O is -2.

In  $\text{K}_2\text{O}_2$ , potassium combines with peroxide ion ( $\text{O}_2^{2-}$ )

Oxidation state of K is +1, of O is -1.

In  $\text{KO}_2$ , potassium combines with superoxide ion ( $\text{O}^{2-}$ ).

Oxidation state of K is +1, of O is -1/2.

**Solution 36:**

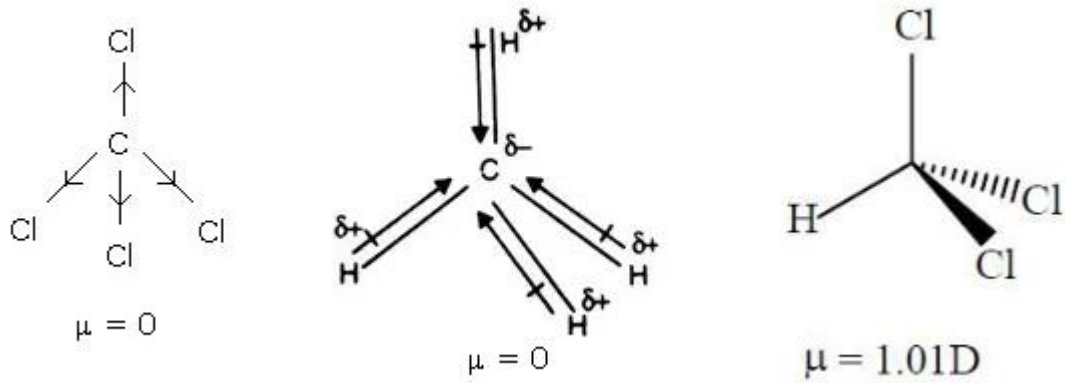

**Solution 37:** Synthetic resins method is more efficient and effective as it can exchange both cations and anions.

**Solution 38:** In the metal-carbonyl  $\pi$  bond is formed by the donation of a pair of electrons from a filled d orbital of metal into the vacant antibonding  $\pi^*$  orbital of carbon monoxide.

**Solution 39:** IUPAC name is: Diamminechloromethylamineplatinum(II)chloride.

**Solution 40:**  $n = 5$ ,  $m_s = +1/2$

Thus, values of  $l$  are from 0 to  $(n-1)$

$l = 0$  to 4

Now, the total number of orbitals =  $n^2 = 5^2 = 25$

**Solution 41:** Fluorine = -333kJ/mol ; Chlorine = -348kJ/mol ; Bromine = -324kJ/mol; Iodine = -295kJ/mol. the correct order is

$\text{Cl} > \text{F} > \text{Br} > \text{I}$

**Solution 42:**

Vitamins	Deficiency Diseases
Vitamin B <sub>1</sub> (Thiamine)	Beriberi
Vitamin B <sub>2</sub> (Riboflavin)	Cheilosis
Vitamin B <sub>6</sub> (Pyridoxine)	Convulsions
Vitamin C (Ascorbic acid)	Scurvy

**Solution 43:** Wrought iron is the purest form of Iron.

**Solution 44:** The order of intermolecular forces is: ion-ion > ion-dipole > dipole-dipole

**Solution 45:** Option c gives Hofmann elimination product.

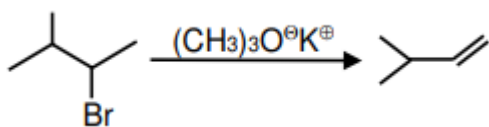

**Solution 46:**

$$\Delta G = \Delta U + 2RT - T\Delta S$$

$$\Delta G = 2.1 + 2 \times 2 \times 300 \times 10^{-3} - 300 \times 20 \times 10^{-3}$$

$$\Delta G = 2.1 + 4 \times 300 \times 10^{-3} - 300 \times 20 \times 10^{-3}$$

$$\Delta G = 1200 \times 10^{-3} - 6000 \times 10^{-3}$$

$$\Delta G = -2.7\text{Kcal}$$

**Solution 47:** All the nuclear reactions follow the first order kinetics.

$$t = \frac{2.303}{k} \log 10$$

$$k = \frac{0.693}{\frac{t_1}{2}}$$

$$k = \frac{0.693}{6.93} = 0.1$$

$$t = \frac{2.303}{0.1}$$

$$t = 23.03 \text{ years}$$

**Solution 48:**

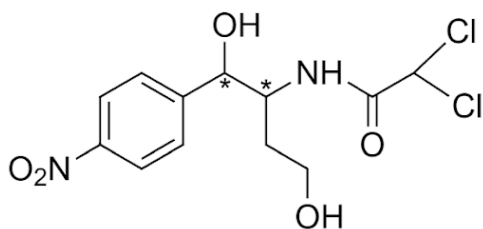

**Solution 49:**

$$\text{Milliequivalents of NaOH} = 40 \times (0.1/100) \times 1 = 0.04$$

$$\text{Milliequivalents of H}_2\text{SO}_4 = 10 \times (0.2/100) \times 2 = 0.02$$

$$\text{Thus, Meq of NaOH left} = 0.04 - 0.02 = 0.02$$

$$\text{pOH} = -\log[4 \times 10^{-4}]$$

$$[\text{OH}^-] = \frac{2}{5} \times 10^{-3}$$

$$\text{pOH} = 3.4$$

$$\text{pH} = 10.5$$

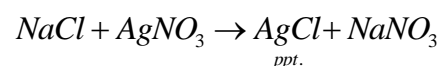
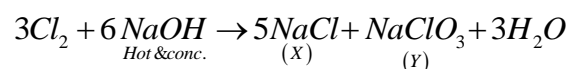
**Solution 50:**

$$\text{Bond order} = \frac{5}{3} = 1.67$$

**MATHEMATICS****Solution 51:**

The equation of the given plane is  $x + y - 2z = 3$ .

$$\text{Now, } \frac{x-2}{1} = \frac{y-1}{1} = \frac{z-6}{-2} = \frac{-2(2+1-12-3)}{6} \Rightarrow (x, y, z) = (6, 5, -2)$$

The angle bisector can be  $\vec{a} = \lambda(\hat{b} + \hat{c})$  or  $\vec{a} = \mu(\hat{b} - \hat{c})$

$$\vec{a} = \lambda \left( \frac{\hat{i} + \hat{j}}{\sqrt{2}} + \frac{\hat{i} + \hat{j} + 4\hat{k}}{3\sqrt{2}} \right) = \frac{\lambda}{3\sqrt{2}} [3\hat{i} + 3\hat{j} + \hat{i} - \hat{j} + 4\hat{k}] = \frac{\lambda}{3\sqrt{2}} [4\hat{i} + 2\hat{j} + 4\hat{k}]$$

Comparing with  $\hat{a} = \alpha\hat{i} + 2\hat{j} + \beta\hat{k}$ , we get the following.

$$\frac{2\lambda}{3\sqrt{2}} = 2 \Rightarrow \lambda = 3\sqrt{2}$$

$$\text{So, } \vec{a} = 4\hat{i} + 2\hat{j} + 4\hat{k}$$

$$\text{We also have } \vec{a} = \mu \left( \frac{\hat{i} + \hat{j}}{\sqrt{2}} - \frac{\hat{i} - \hat{j} + 4\hat{k}}{3\sqrt{2}} \right) = \frac{\mu}{3\sqrt{2}} (3\hat{i} + 3\hat{j} - \hat{i} + \hat{j} - 4\hat{k}) = \frac{\mu}{3\sqrt{2}} (2\hat{i} + 4\hat{j} - 4\hat{k})$$

Comparing with  $\vec{a} = \alpha\hat{i} + 2\hat{j} + \beta\hat{k}$ , we have the following.

$$\frac{4\mu}{3\sqrt{2}} = 2 \Rightarrow \mu = \frac{3\sqrt{2}}{2}$$

$$\text{So, } \vec{a} = \hat{i} + 2\hat{j} - 2\hat{k}$$

$$\text{Now, } \vec{a} \cdot \hat{k} + 2 - 2 + 2 = 0$$

**Solution 52:**

For the given system to have a non-trivial solution, we must have the following condition.

$$\begin{vmatrix} 2 & 2a & a \\ 2 & 3b & b \\ 2 & 4c & c \end{vmatrix} = 0, \text{ that is, } \begin{vmatrix} 1 & 2a & a \\ 1 & 3b & b \\ 1 & 4c & c \end{vmatrix} = 0$$

$$(3bc - 4bc) - (2ac - 4ac) + (2ab - 3ab) = 0$$

$$-bc + 2ac - ab = 0$$

$$ab + bc = 2ac$$

$a, b, c$  in HP

$$\Rightarrow \frac{1}{a}, \frac{1}{b}, \frac{1}{c} \text{ are in AP}$$

**Solution 53:**

$$\frac{(49)^{126} - 1}{48} = \frac{((49)^{63} + 1)(49^{63} - 1)}{48}$$

**Solution 55:**

$$y = \sqrt{\frac{2 \cos^2 \alpha}{\sin \alpha \cos \alpha} + \frac{1}{\sin^2 \alpha}} = \sqrt{2 \cot \alpha + \operatorname{cosec}^2 \alpha} = |1 + \cot \alpha| = -1 - \cot \alpha$$

$$\therefore \frac{dy}{d\alpha} = \operatorname{cosec}^2 \alpha$$

$$\text{So, } \left( \frac{dy}{d\alpha} \right)_{\alpha = \frac{5\pi}{6}} = 4$$

**Solution 56:**

$$A^2 = \frac{1}{3} \begin{bmatrix} 1 & 1 & 1 \\ 1 & \omega & \omega^2 \\ 1 & \omega^2 & \omega \end{bmatrix} \begin{bmatrix} 1 & 1 & 1 \\ 1 & \omega & \omega^2 \\ 1 & \omega^2 & \omega \end{bmatrix} = \begin{bmatrix} 1 & 0 & 0 \\ 0 & 0 & 1 \\ 0 & 1 & 0 \end{bmatrix} = I$$

Clearly,  $A^4 = I$



$$\text{So, } A^{30} = A^{28} \times A^3 = A^3$$

**Solution 57:**

We have  $2ae = 6$  and  $\frac{2a}{e} = 12$ , that is  $ae = 3$  and  $\frac{a}{e} = 6$ .

Solving, we get  $a^2 = 18$

$$\Rightarrow b^2 = a^2 - a^2 e^2 = 18 - 9 = 9$$

$$\text{So, LR} = \frac{2b^2}{a} = \frac{2 \times 9}{3\sqrt{2}} = 3\sqrt{2}$$

**Solution 58:**

$$y = mx + 4 \dots(i)$$

Tangent of slope  $m$  to  $y^2 = 4x$  is  $y = mx + \frac{a}{m} \Rightarrow y = mx + \frac{1}{m} \dots(ii)$

From equations (i) and (ii), we have the following.

$$4 = \frac{1}{m} \Rightarrow m = \frac{1}{4}$$

Since the line  $y = \frac{1}{4}x + 4$  is also a tangent to the parabola  $x^2 = 2by$ ,

we get the following

$$x^2 = 2b \left( \frac{x+16}{4} \right)$$

$$\Rightarrow 2x^2 - bx - 16b = 0$$

Now, discriminant should be 0, so we have the following.

$$b^2 - 4 \times 2 \times (-16b) = 0$$

$$\Rightarrow b^2 + 32 \times 4b = 0 \Rightarrow b = -128, 0$$

which is not possible.

**Solution 59:**

Let  $e^y = t$

$$\text{So, we have } e^y \frac{dy}{dx} = \frac{dt}{dx}$$

Thus, the differential equation is  $\frac{dt}{dx} - t = e^x$

Now, the integrating factor is  $IF = e^{\int -1 \cdot dx} = e^{-x}$

So, the solution is given by  $t(e^{-x}) = \int e^x \cdot e^{-x} dx$

That is,  $e^{y-x} = x + c$

Substituting  $x=0, y=0$  we get  $c=1$

So, the particular solution is  $e^{y-x} = x+1$

That is,  $y = x + \ln(x+1)$

Now, at  $x=1, y = 1 + \ln(2)$

**Solution 60:**

Consider the odd digits 1, 3, 5, 7, 9

For digits to repeat we have  ${}^5C_1$  choice

And six digits can be arranged in  $\frac{6!}{2!}$  ways.

Hence, total number of such numbers =  $\frac{5 \times 6!}{2!}$

**Solution 61:**

Let the terms in AP be  $a-2d, a-d, a, a+d, a+2d$ .

Since their sum = 25  $\Rightarrow 5a = 25 \Rightarrow a = 5$

Also, their product = 2520

That is,  $(5-2d)(5-d)5(5+d)(5+2d) = 2520$

$$\Rightarrow (25 - 4d^2)(25 - d^2) = 504$$

$$\Rightarrow 625 - 100d^2 - 25d^2 + 4d^4 = 504$$

$$\Rightarrow 4d^4 - 125d^2 + 625 - 504 = 0$$

$$\Rightarrow 4d^4 - 125d^2 + 121 = 0$$

$$\Rightarrow 4d^4 - 121d^2 - 4d^2 + 121 = 0$$

$$\Rightarrow (d^2 - 1)(4d^2 - 121) = 0$$

$$\Rightarrow d = \pm 1, \pm \frac{11}{2}$$

Using  $d = \pm 1$  does not give  $\frac{-1}{2}$  as a term of the sequence

$$\therefore d = \frac{11}{2}$$

$\therefore$  Largest term in the sequence =  $5 + 2d = 5 + 11 = 16$

**Solution 62:**

$p$	$q$	$p \rightarrow q$	$\sim p$	$q \rightarrow \sim p$	$(p \rightarrow q) \wedge (q \rightarrow \sim p)$
T	T	T	F	F	F
T	F	F	F	T	F

F	T	T	T	T	T
F	F	T	T	T	T

From the truth table, it is evident that  $(p \rightarrow q) \wedge (q \rightarrow \sim p)$  is equivalent to  $\sim p$

**Solution 63:**

Consider the equation  $(k+1)\tan^2 x - \sqrt{2}\lambda \tan x + (k-1) = 0$

By using relationship of roots with coefficients, we get the following.

$$\tan \alpha + \tan \beta = \frac{\sqrt{2}\lambda}{k+1} \text{ and } \tan \alpha \tan \beta = \frac{k-1}{k+1}$$

$$\text{Now, } \tan(\alpha + \beta) = (k-1) = 0 \frac{\frac{\sqrt{2}\lambda}{k+1}}{1 - \frac{k-1}{k+1}} = \frac{\sqrt{2}\lambda}{2} = \frac{\lambda}{\sqrt{2}}$$

$$\text{So, } \tan^2(\alpha + \beta) = \frac{\lambda^2}{2} = 50$$

Hence,  $\lambda = 10$

**Solution 64:**

We have  $g(f(x)) = f^2(x) + f(x) - 1$

$$\text{So, } g\left(f\left(\frac{5}{4}\right)\right) = 4\left(\frac{5}{4}\right)^2 - 10 \times \frac{5}{4} + 5 = -\frac{5}{4}$$

$$\text{Now, } g\left(f\left(\frac{5}{4}\right)\right) = f^2\left(\frac{5}{4}\right) + f\left(\frac{5}{4}\right) - 1$$

$$\text{Comparing both, we have } -\frac{5}{4} = f^2\left(\frac{5}{4}\right) + f\left(\frac{5}{4}\right) - 1$$

$$\text{That is, } f^2\left(\frac{5}{4}\right) + f\left(\frac{5}{4}\right) + \frac{1}{4} = 0 \text{ or } \left(f\left(\frac{5}{4}\right) + \frac{1}{2}\right)^2 = 0$$

$$\text{So, } f\left(\frac{5}{4}\right) = -\frac{1}{2}$$

**Solution 65:**

$$\text{Let } I = \frac{1}{(a+b)} \int_a^b x[f(x) + f(x+1)] dx \dots (1)$$

Using property and making the substitution  $x \rightarrow a+b-x$ , we get the following.

$$I = \frac{1}{(a+b)} \int_a^b (a+b-x) [f(a+b-x) + f(a+b+1-x)] dx$$

$$\text{That is, } I = \frac{1}{(a+b)} \int_a^b (a+b-x) [f(x+1) + f(x)] dx \dots (2)$$

[By putting  $x \rightarrow x+1$  in the given equation]

Now, adding (1)+(2), we get the following.

$$2I = \int_a^b [f(x+1) + f(x)] dx$$

$$2I = \int_a^b f(x+1) dx + \int_a^b f(x) dx$$

$$\int_a^b f(a+b+1-x) dx + \int_a^b f(x) dx$$

$$\text{That is, } 2I = 2 \int_a^b f(x) dx$$

$$\text{So, } I = \int_a^b f(x) dx$$

$$\text{Now, putting } x = t+1, \text{ we get } I = \int_{a-1}^{b-1} f(t+1) dt$$

### Solution 66:

Consider  $z = x + iy$

$$\text{So, } \left( \frac{z-1}{2z+i} \right) = \frac{(x-1)+iy}{2(x+iy)+i} = \frac{(x-1)+iy}{2x+(2y+1)i} \times \frac{2x-(2y+1)i}{2x-(2y+1)i}$$

$$\text{So, we have } \operatorname{Re} \left( \frac{z+1}{2z+i} \right) = \frac{2x(x-1)+y(2y+1)}{(2x)^2+(2y+1)^2} = 1$$

$$\Rightarrow 2x^2 + 2y^2 - 2x + y = 4x^2 + 4y^2 + 4y + 1 \Rightarrow 2x^2 + 2y^2 + 2x + 3y + 1 = 0$$

$$\Rightarrow x^2 + y^2 + x + \frac{3}{2}y + \frac{1}{2} = 0$$

This equation represents a circle centred at  $\left( -\frac{1}{2}, -\frac{3}{4} \right)$

$$\text{Now, its radius } r = \sqrt{\frac{1}{4} + \frac{9}{16} - \frac{1}{2}} = \sqrt{\frac{4+9-8}{16}} = \frac{\sqrt{5}}{4}$$

### Solution 67:

We can find the total area minus the enclosed area as in the diagram shown, as follows.

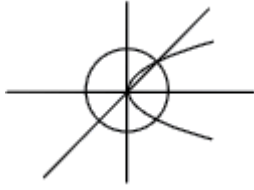

$$\text{Area} = 2\pi - \int_0^1 \sqrt{x} - x \, dx = 2\pi - \left( \frac{2x^{3/2}}{3} - \frac{x^2}{2} \right)_0^1 = 2\pi - \left( \frac{2}{3} - \frac{1}{2} \right) \Rightarrow 2\pi - \left( \frac{1}{6} \right) \Rightarrow \frac{12\pi - 1}{6}$$

**Solution 68:**

$k$	0	1	2	3	4	5
$P(k)$	$\frac{1}{32}$	$\frac{12}{32}$	$\frac{11}{32}$	$\frac{5}{32}$	$\frac{2}{32}$	$\frac{1}{32}$

Here,  $k$  = number of times heads occur consecutively.

So, the expected value is given as follows.

$$\sum xP(k) = (-1) \times \frac{1}{32} + (-1) \times \frac{12}{32} + (-1) \times \frac{11}{32} + 3 \times \frac{5}{32} + 4 \times \frac{2}{32} + 5 \times \frac{1}{32} = \frac{1}{8}$$

**Solution 69:**

Using LMVT on the function on the interval  $x \in [-7, -1]$ , we have the following.

$$\frac{f(-1) - f(-7)}{(-1+7)} \leq 2$$

That is,  $\frac{f(-1)+3}{6} \leq 2 \Rightarrow f(-1) \leq 9$

Using LMVT on the function on the interval  $x \in [-7, 0]$ , we have the following.

$$\frac{f(0) - f(-7)}{(0+7)} \leq 2$$

That is,  $\frac{f(0)+3}{7} \leq 2 \Rightarrow f(0) \leq 11$

$\therefore f(0) + f(-1) \leq 20$

**Solution 70:**

Consider  $kx^{k-1} + ky^{k-1} \frac{dy}{dx} = 0$

This gives us  $\frac{dy}{dx} = -\left(\frac{x}{y}\right)^{k-1}$  or  $\frac{dy}{dx} + \left(\frac{x}{y}\right)^{k-1} = 0$

Now,  $k-1 = -\frac{1}{3}$  or  $k = 1 - \frac{1}{3} = \frac{2}{3}$

**Solution 71:**

Since  $f(x)$  is non differentiable at  $x = 1, 3, 5$ , we have the following.

$$\sum f(f(x)) = f(f(1)) + f(f(3)) + f(f(5)) = 1 + 1 + 1 = 3$$

**Solution 72:**

$$\text{Var}(1, 2, \dots, n) = 10 \Rightarrow \frac{1^2 + 2^2 + \dots + n^2}{n} - \left(\frac{1 + 2 + \dots + n}{n}\right)^2 = 10$$

$$\Rightarrow \frac{(n+1)(2n+1)}{6} - \left(\frac{n+1}{2}\right)^2 = 10$$

$$\Rightarrow n^2 - 1 = 120 \Rightarrow n = 11$$

$$\text{Var}(2, 4, 6, \dots, 2m) = 16 \Rightarrow \text{var}(1, 2, \dots, m) = 4$$

$$\Rightarrow m^2 - 1 = 48 \Rightarrow m = 7$$

So,  $m + n = 18$

**Solution 73:**

Clearly, P is the centroid of  $\Delta ABC$

So,  $P\left(\frac{17}{6}, \frac{8}{3}\right)$

Thus,  $PQ = \sqrt{\left(\frac{24}{6}\right)^2 + \left(\frac{9}{3}\right)^2} = 5$

**Solution 74:**

Let  $3^{x/2} = t$

$$\text{So, } \lim_{t \rightarrow 3} \frac{t^2 + \frac{27}{t^2} - 12}{\frac{1}{t} - \frac{3}{t^2}} = \lim_{t \rightarrow 3} \frac{t^4 + 27 - 12t^2}{t - 3} = \lim_{t \rightarrow 3} \frac{(t^2 - 3)(t + 3)(t - 3)}{(t - 3)} = 6 \times 6 = 36$$

**Solution 75:**

Let  $(1 - x + x^2 - x^3 + \dots)(1 + x + x^2 + \dots) = a_0 + a_1x + a_2x^2 + \dots$

Substituting  $x = 1$ , we get the following.

$$2n+1 = a_0 + a_1 + a_2 + \dots + a_{2n} \quad \dots(i)$$

Substituting  $x = -1$ , we get the following.

$$2n+1 = a_0 - a_1 + a_2 + \dots - a_{2n} \quad \dots(ii)$$

Adding equations (i) + (ii), we get

$$4n+2 = 2(a_0 + a_2 + \dots) = 2 \times 61$$

$$\Rightarrow 2n+1 = 61 \Rightarrow n = 30$$